

# RCM1 with EtherCAT®

NEMA Size 17 and 23 Cool Muscle Motor servo system with EtherCAT®

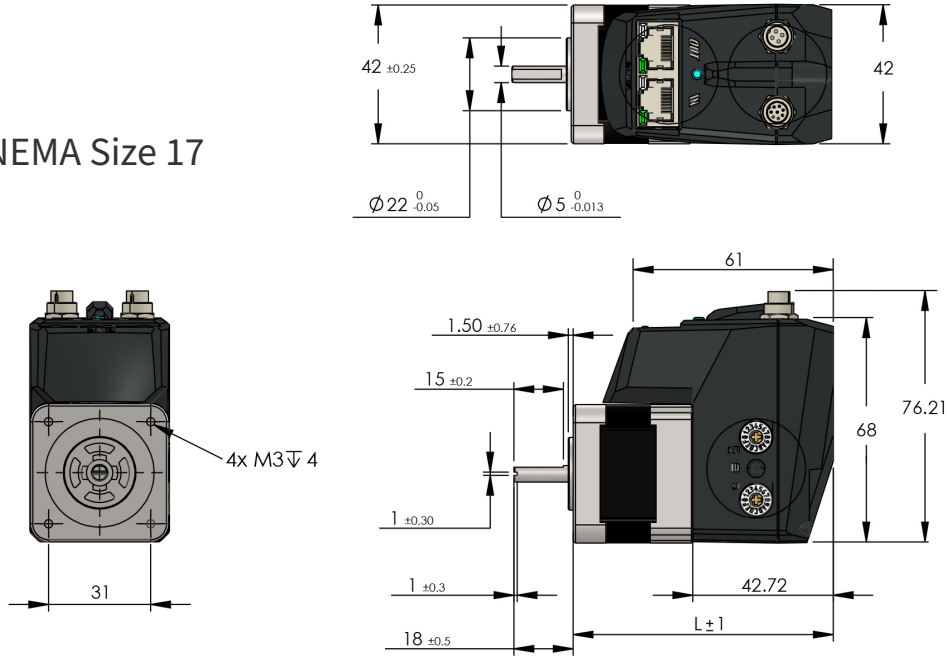

NEMA Size 17



## Key Features

- Integrated servo system including 50,000 CPR encoder, sinusoidal vector drive and real-time controller
- EtherCAT® feature is available integrated or separately through the EtherCAT® Bridge
- A standardised protocol which can easily be implemented in systems using the EtherCAT® interface
- The power of the driver and controller can be operated separately, allowing for absolute position and increased safety
- Standard I/O (4 inputs/2 outputs). Additionally, the output is designed for an inductive load, meaning 1 Amp can be run directly from the output
- CSP, CSV, PP and CV motion profiles

## Part number structure

### RCM1 - E - 17 S 30 - C - RT3

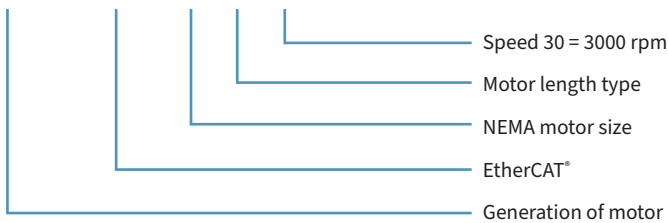

## Motor specification

Part Number	Length L mm	Weight kg	Input Voltage	Peak Torque Nm	Peak Current A	Peak Speed rpm
RCM1-E-17S30	79	0.4	24V ± 10%	0.117	1.0	3000
RCM1-E-17L30	94	0.56		0.54	1.8	3000

## RCM1 with EtherCAT®

NEMA Size 17 and 23 Cool Muscle Motor servo system with EtherCAT®

NEMA Size 23

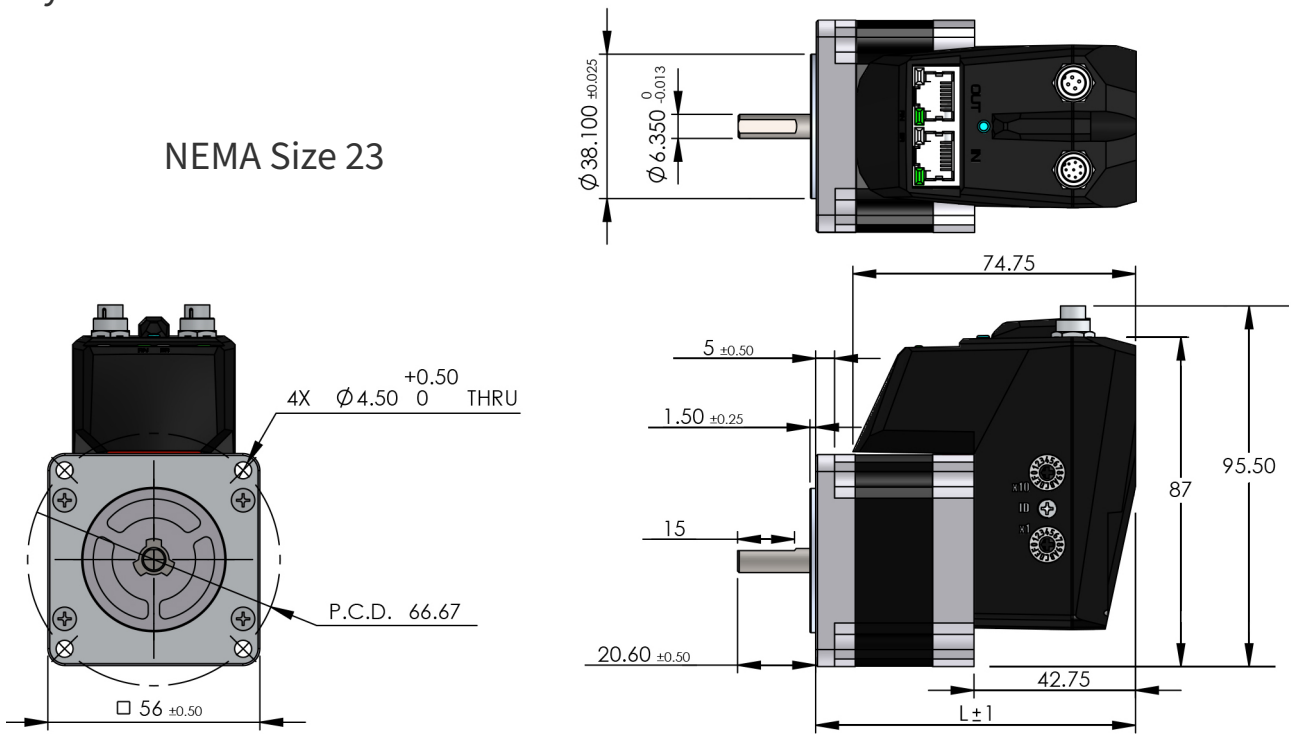

### Key Features

- Integrated servo system including 50,000 CPR encoder, sinusoidal vector drive and real-time controller
- EtherCAT® feature is available integrated or separately through the EtherCAT® Bridge
- A standardised protocol which can easily be implemented in systems using the EtherCAT® interface
- The power of the driver and controller can be operated separately, allowing for absolute position and increased safety
- Standard I/O (4 inputs/2 outputs). Additionally, the output is designed for an inductive load, meaning 1 Amp can be run directly from the output
- CSP, CSV, PP and CV motion profiles

### Part number structure

## RCM1 - E - 23 S 20 - C - RT3

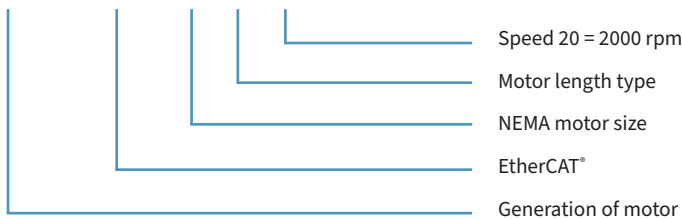

### Motor specification

Part Number	Length L mm	Weight kg	Input Voltage	Peak Torque Nm	Peak Current A	Peak Speed rpm
RCM1-E-23S30	84.5	0.62	24V ± 10%	0.46	5.1	3000
RCM1-E-23L20	118.5	1.18		1.24	3.4	2000

## Torque curve

RCM1-□-17S30

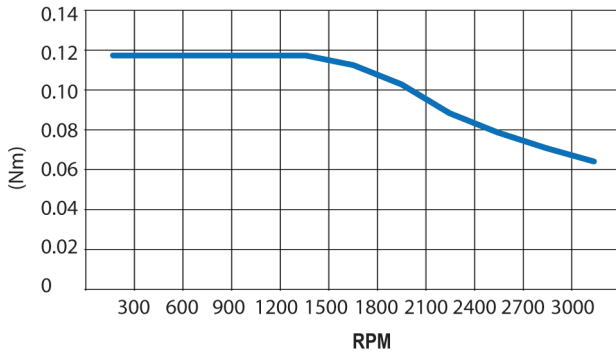

RCM1-□-17L30

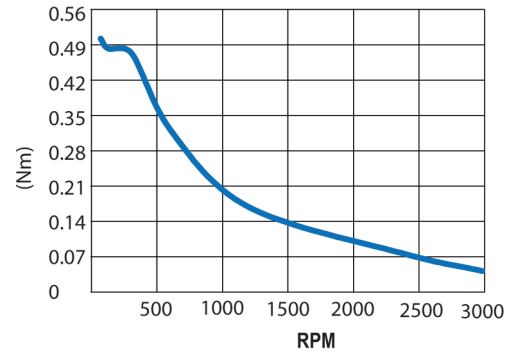

RCM1-□-23S30

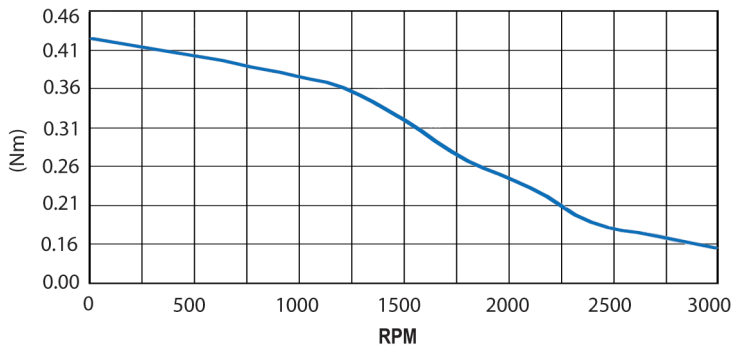

RCM1-□-23L20

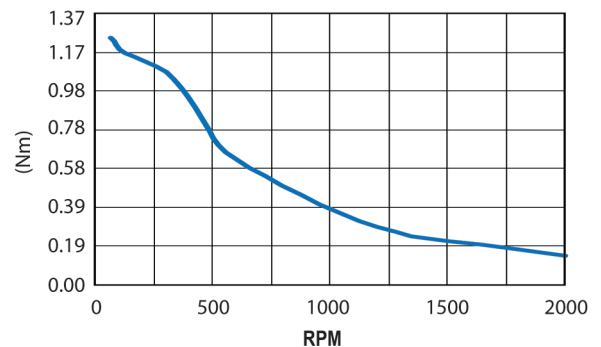

## Product overview

The Cool Muscle integrated servo system has been a premium, reliable product in the Reliance motion control range for many years. The company is pleased to announce an extension to the range, with the EtherCAT® compatible servo motors.

EtherCAT® is a high speed, real time communication protocol that has the ability to update numerous devices in the microsecond range. This makes it ideal for multi-axis synchronised control or in systems where a master is coordinating a large variety of devices such as sensors, motion axes, distributed IO, etc.

The nema size 17 and 23 Cool Muscle motors are available with integrated EtherCAT® communication. All other models are available with the EtherCAT® Cool Muscle Bridge.

The Cool Muscle motors are also available with Modbus/TCP, Ethernet IP, RS-232, RS-485 and USB interface. The motors can be used in numerous applications. Examples include:

- Automation
- Robotics
- Labelling Systems
- Semi-Conductor manufacture and test instruments
- Laboratory Instrumentation
- Medical devices
- Entertainment (automated devices, displays etc)

The Cool Muscle Motors can be integrated into tested, reliable complete solutions such as the Reliance Cool Motion Stage, solid and tubular rack actuators and the RCSR captive actuator.

