

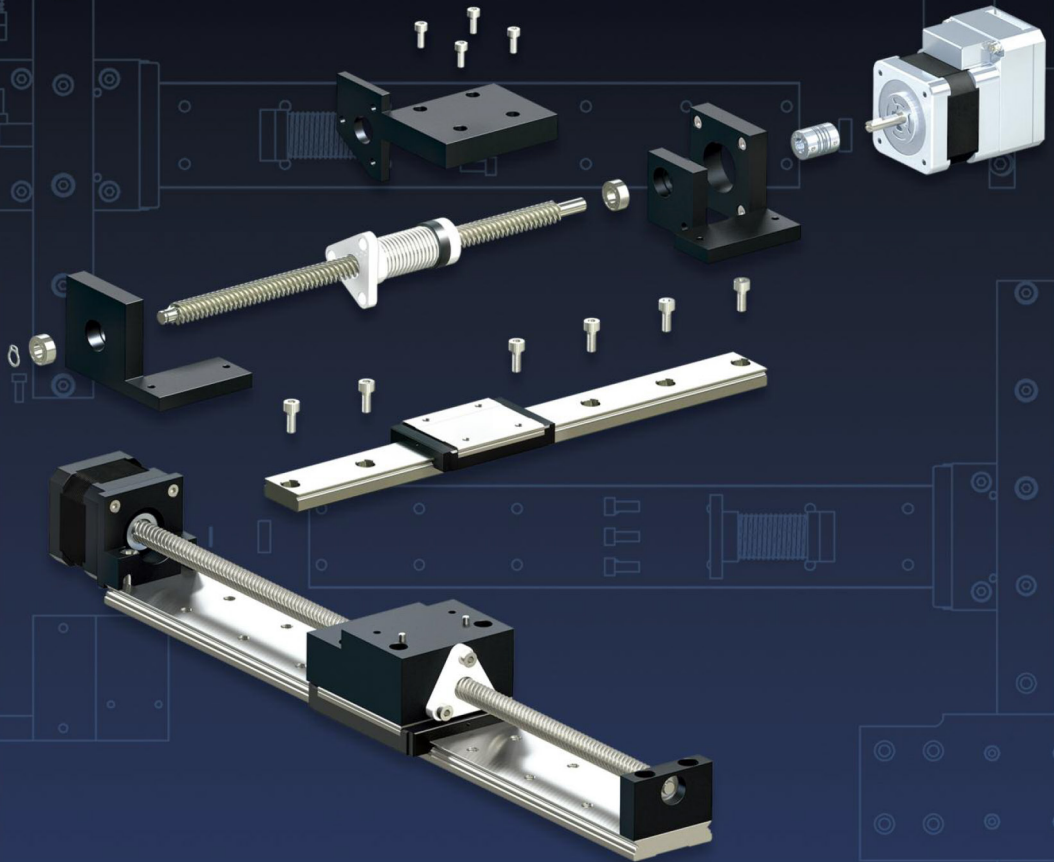

RELIANCE™

P R E C I S I O N



Precise Motion Control Solutions
Round and Rectangular Racks and Pinions

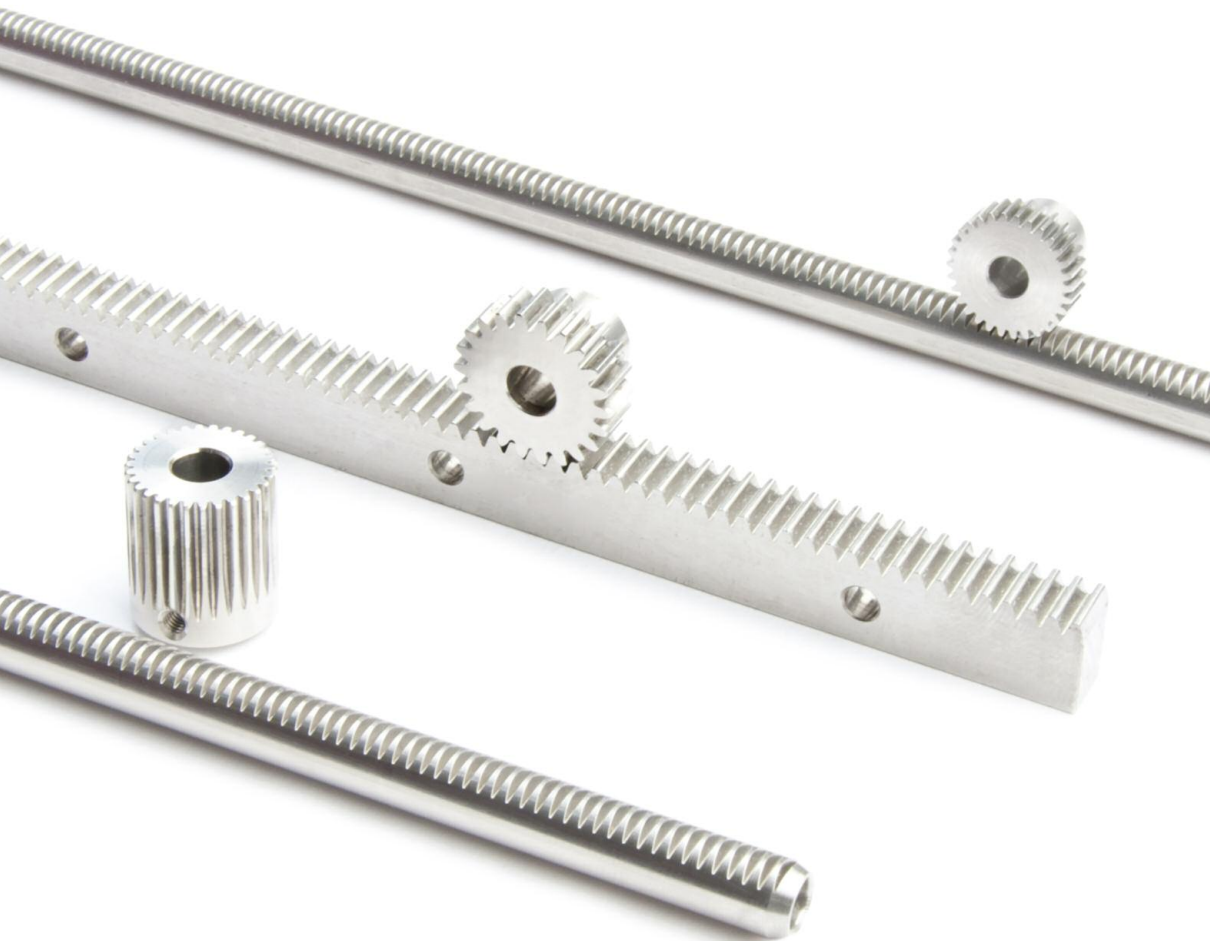

Section Contents

Racks and Pinions - OverviewPage 6-2

Precision Ground Rack - Hardened RectangularPage 6-3

Precision Ground Rack - Hardened RoundPage 6-4

Precision Ground Rack - Soft Round SolidPage 6-5

Precision Ground Rack - Soft Round TubularPage 6-6

Precision Hobbed Rack - Soft Round.....Page 6-7

Precision Hobbed Rack - Soft RectangularPage 6-8

Hobbed Brass Rack - RectangularPage 6-9

Plain Rack PinionsPage 6-10

Hardened Rack PinionsPage 6-10

Anti-backlash Rack PinionsPage 6-11

Technical Information.....Page T6-1



Accurate conversion from rotary to linear motion

A rack and pinion system gives the ability to transfer rotary to linear motion, with all the accuracy expected of a geared system.



The racks are manufactured from ground, hardened stainless steel or ground stainless steel and available with a choice of accuracies, pitches, and lengths, plus the facility to provide modifications such as flats, journals or custom ends. Hobbed stainless steel and brass racks are also available. The rack pinions are plain or anti-backlash, also with a choice of accuracies, pitches, bore sizes, alternative materials and coatings.

Ground racks can be used for both measurement and actuation. In general the smaller pitches (1 mm) suit measurement as the smaller pinion diameter gives higher linear resolutions. The larger pitches (2 mm and 2.5 mm) allow for a higher load capacity. For most applications the rack can be used for both the feedback and the actuation; however in very precise applications it is best to use a non-drive section of the rack for feedback, alternatively a separate rack can be used. Hobbed racks are more suited to light actuation applications where cost is a key consideration.

We offer three types of rack – rectangular racks, solid round racks and tubular racks. Rectangular racks are used when the application requires the rack to be stationary and the rack pinion provides the element of motion. Our rectangular racks are used with a motor, slide and carriage for example in the printing industry for the actuation of paper cutting knives in a printing press. Round racks are a more flexible alternative, with regard to mounting, used for example in XY stages. The tubular racks allow for the passage of fluids, fibre-optics, gasses etc, making them ideal for medical and scientific applications, such as laboratory automation pick and place mechanisms.

For a fully integrated solution the Racktuator™ (see [page 2-14](#)) is a combined rack and intelligent motor actuation system. Bringing together Reliance's racks and Cool Muscle servo system, the Racktuator™ provides a very high level of control and accuracy in a compact, space saving package.

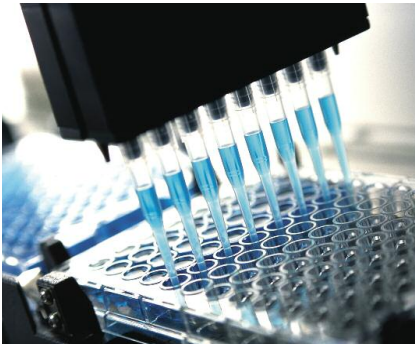

Laboratory automation systems



Printing automation systems

Precision Ground Rack Hardened Rectangular

1, 2 & 2.5mm
Circular Pitch



Associated Products
Rack pinions: page 6-10

All dimensions in mm
Material: Stainless steel grade 416
Treatment: Hardened to 35-45 HRC
Pressure angle 20°

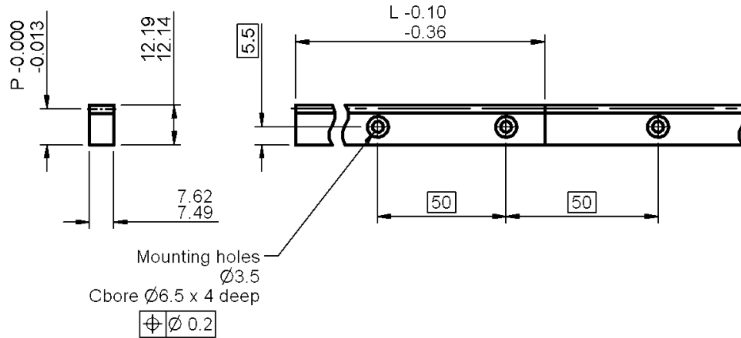

Part number selection table

Part Number	Circular Pitch (mm)	Length L	Pitch Height P	Number of Holes
R9-1M-300	1	300	11.869	6
R9-2M-300	2		11.550	
R9-25M-300	2.5		11.391	



i Features and options

- Cumulative pitch error less than 0.008 mm per 300 mm
- Ground teeth, accuracy grade 4 as standard
- Alternative grades available - see [page T6-1](#)
- Unlimited axis lengths possible by setting individual racks together
- Shorter lengths available
- Alternative pitches, including module

? Technical support

- Installation information - see [page T6-4](#)
- Technical information - see [pages T6-1 to T6-6](#)
- PTFE based grease is recommended for lubrication
- For modified or fully bespoke racks, please contact us



Ø12mm
2mm Circular Pitch

Precision Ground Rack Hardened Round

All dimensions in mm
General tolerances ± 0.13 mm
Material: Linear bearing shaft
stainless steel grade 440C
or X90CrMoV18
Treatment: Case hardened to
55 HRc min
Pressure angle 20°

Associated Products
Rack pinions: page 6-10

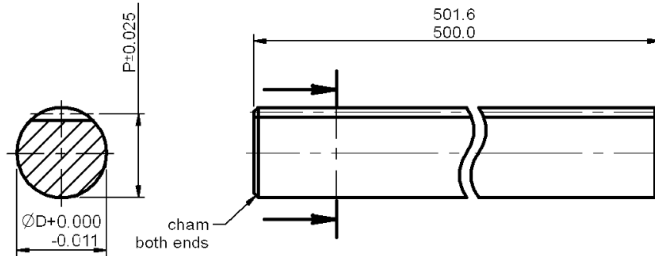

Part number selection table

Part Number	Circular Pitch (mm)	Outer Dia $\varnothing D$	Pitch Height P	Rack Thrust (N)
RR12-1M-500	1	12	11.841	30*
RR12-2M-500	2		11.682	60*

* Rack thrust based on meshing with a 60 tooth hardened rack pinion, theoretically calculated.



i Features and options

- Cumulative pitch error less than 0.025 mm
- Ground teeth, accuracy grade 3 as standard
- Higher accuracy grades available
- Bearing surface and drive in one component
- Shorter lengths available
- Alternative pitches available
- Flats, journals and end modifications

? Technical support

- Installation information - see [page T6-4](#)
- Technical information - see [pages T6-1 to T6-6](#)
- PTFE based grease is recommended for lubrication
- Can be used with both open and closed linear bearings with either 4, 5 or 6 ball tracks (the bearing must be positioned so the balls do not run on the edges of the teeth - see [page T6-3](#)).
- For modified or fully bespoke racks, please contact us



Associated Products

Rack pinions - CP: page 6-10

Rack pinions - Module: page 4-12

All dimensions in mm
General tolerances ± 0.13 mm
Material: Stainless steel grade 300
Pressure angle 20°

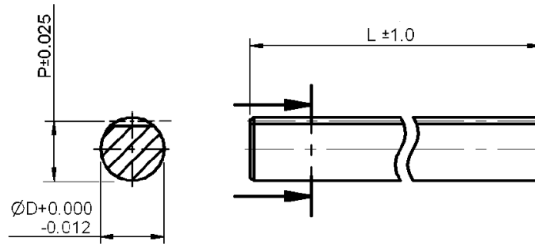

Part number selection table

Part Number	Pitch (mm)	Length L	Outer Dia ØD	Bore Dia Ød	Pitch Height P	Rack Thrust (N)
RRS06-1M-500	1 mm CP	500	6	-	5.682	20*
RRS10-050-500	0.5 module	500	10	-	9.500	40*

* Rack thrust based on meshing with a 50 tooth stainless steel pinion, 3 N if used with a 50 tooth PEEK polymer pinion.



i Features and options

- Cumulative pitch error less than 0.050 mm
- Ground teeth, accuracy grade 2 as standard
- High resistance to pitting corrosion
- Flats, journals and end modifications
- Ideal for medical and scientific applications
- Bearing surface and drive in one component
- Shorter lengths available
- Alternative pitches available

? Technical support

- Installation information - see [page T6-4](#)
- Technical information - see [pages T6-1 to T6-6](#)
- PTFE based grease is recommended for lubrication
- For modified or fully bespoke racks, please contact us



1mm Circular Pitch 0.3 Module

Precision Ground Rack Soft Round Tubular

All dimensions in mm
General tolerances ± 0.13 mm
Material: Stainless steel grade 316
Pressure angle 20°

Associated Products
Rack pinions - CP: page 6-10
Rack pinions - Module: page 4-12

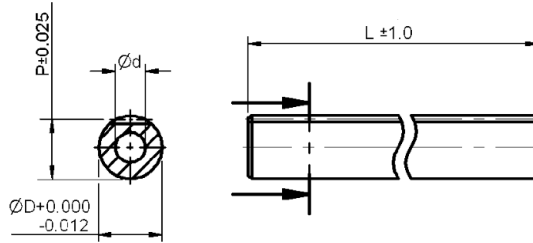

Part number selection table

Part Number	Pitch (mm)	Length L	Outer Dia $\varnothing D$	Bore Dia $\varnothing d$	Pitch Height P	Rack Thrust (N)
RRT06-1M-500	1 mm CP	500	6	3.6	5.682	20*
RRT06-030-500	0.3 module				5.700	

* Rack thrust based on meshing with a 50 tooth stainless steel pinion, 3 N if used with a 50 tooth PEEK polymer pinion.



i Features and options

- Cumulative pitch error less than 0.050 mm
- Ground teeth, accuracy grade 2 as standard
- High resistance to pitting corrosion
- Hollow shaft allows for the passage of fluids, fibre-optics and gasses etc
- Ideal for medical and scientific applications
- Bearing surface and drive in one component
- Flats, journals and end modifications
- Shorter lengths available
- Alternative pitches available

? Technical support

- Installation information - see [page T6-4](#)
- Technical information - see [pages T6-1 to T6-6](#)
- PTFE based grease is recommended for lubrication
- For modified or fully bespoke racks, please contact us

Precision Hobbed Rack Soft Round

0.5, 0.75, 0.8
& 1.0 Module



Associated Products
Rack pinions: page 4-12

All dimensions in mm
Material: Stainless steel grade 304
Pressure angle 20°

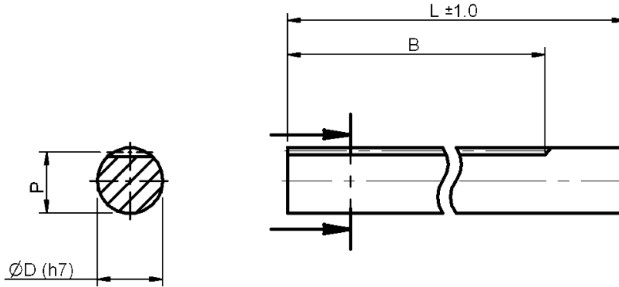

Part number selection table

Part Number	Module	Number of Teeth	Length L	Pitch Height P	Extent of Teeth B	Diameter D	Weight (g)
ORK50SU2-0815	0.5	95	202	7.5	149	8	78
ORK75SU2-0815	0.75	63	202	7.25	148	8	76
ORK80SU2-0815	0.8	59	202	7.2	148	8	76
ORK1SU3-1024	1.0	76	305	9.0	238	10	177



i Features and options

- Longer tooth lengths available, please contact us

? Technical support

- PTFE based grease is recommended for lubrication
- Installation information - see [page T6-4](#)
- Technical information - see [pages T6-1 to T6-6](#)
- For modified or fully bespoke racks, please contact us



0.5, 0.75, 0.8 & 1.0 Module

Precision Hobbed Rack Soft Rectangular

All dimensions in mm
Material: Stainless steel grade 304
Pressure angle 20°

Associated Products
Rack pinions: page 4-12

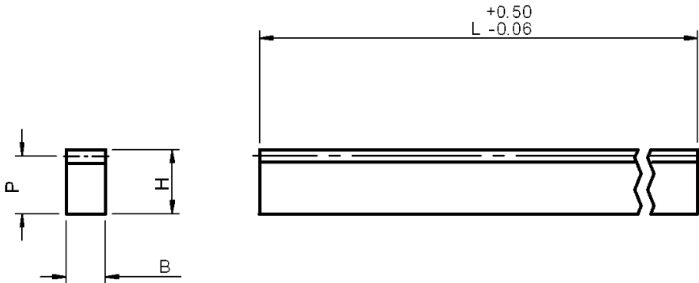

Part number selection table

Part Number	Module	Number of Teeth	Length L	Pitch Height P	Face width B (h12)	Height H (h12)	Weight (g)
RK50SU2-0310	0.5	126	202~205	9.5	3	10	45
RK50SU2-0808				7.5	8	8	95
RK75SU2-0310	0.75	83	202~205	9.25	3	10	44
RK75SU2-0808				7.25	8	8	91
RK80SU5-0510	0.8	198	505~508	9.2	5	10	183
RK1SU5-0810	1.0	158	505~508	9	8	10	280



i Features and options

- Racks are manufactured from cold drawn stainless steel

? Technical support

- PTFE based grease is recommended for lubrication
- Installation information - see [page T6-4](#)
- Technical information - see [pages T6-1 to T6-6](#)
- For modified or fully bespoke racks, please contact us

Hobbed Brass Rack Rectangular

0.3, 0.5, 0.75
& 0.8 Module



Associated Products
Rack pinions: page 4-12

All dimensions in mm
Material: Brass grade CuZn39Pb3
Pressure angle 20°

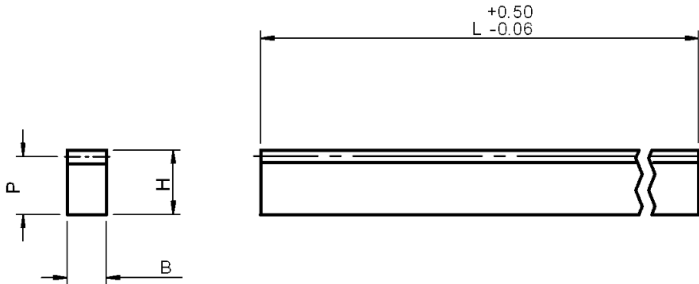

Part number selection table

Part Number	Module	Number of Teeth	Length L	Pitch Height P	Face width B (h11)	Height H (h11)	Weight (g)
RK30B2-0308	0.3	210	200	7.7	3	8	38
RK50B2-0808	0.5	125	200	7.5	8	8	98
RK75B2-0808	0.75	82	200	7.25	8	8	95
RK80B5-0510	0.8	198	505	9.2	5	10	191



i Features and options

- Brass racks, ideal for lightly loaded applications, an economic balance of accuracy and load capacity against cost
- Manufactured from cold drawn material

? Technical support

- Installation information - see [page T6-4](#)
- Technical information - see [pages T6-1 to T6-6](#)
- For modified or fully bespoke racks, please contact us



6 mm & 10 mm Bore

Plain and Hardened Rack Pinions

Associated Products
Racks: page 6-3

All dimensions in mm
General tolerances ± 0.13 mm
Material: Hardened pinions - 17-4 PH,
35-42HRc
Plain pinions - Stainless steel 316
Pressure angle 20°

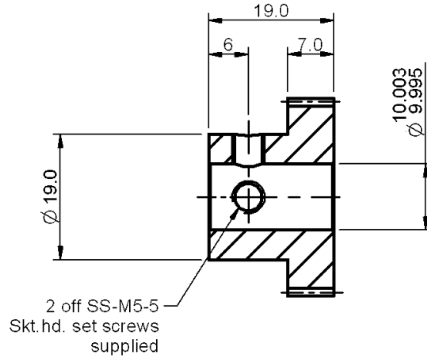
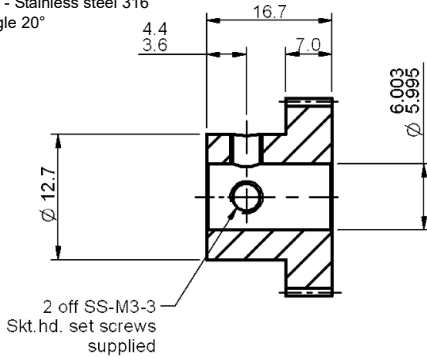

Part number selection table

Example Part No:- **SH25MS2B6F7A- 32**

Basic Part Number		Circular Pitch (mm)	Bore Size	Number of Teeth	
Plain	Hardened			Min	Max
SH1MS2B6F7A-	SH1MS8B6F7A-	1	6	43	111
SH2MS2B6F7A-	SH2MS8B6F7A-	2		23	54
SH25MS2B6F7A-	SH25MS8B6F7A-	2.5		19	43
SH1MS2B10F7A-	SH1MS8B10F7A-	1	10	63	104
SH2MS2B10F7A-	SH2MS8B10F7A-	2		33	51
SH25MS2B10F7A-	SH25MS8B10F7A-	2.5		27	40

i Features and options

- Standard accuracy AQ10 - see [page T4-1](#)
- Hardened pinions provide longer pinion life, higher load capacity and higher thrust
- Higher accuracies available
- Alternative pitches available
- Alternative bore sizes, including imperial available
- Alternative materials available
- Special wear resistant coating available
- For modified or fully bespoke pinions, please contact us





Associated Products
Racks: page 6-3

All dimensions in mm
General tolerances ± 0.13 mm
Pressure angle 20°
Material: Stainless steel 316

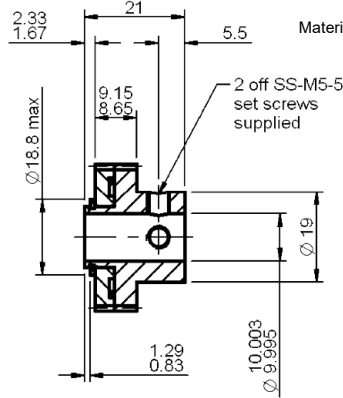
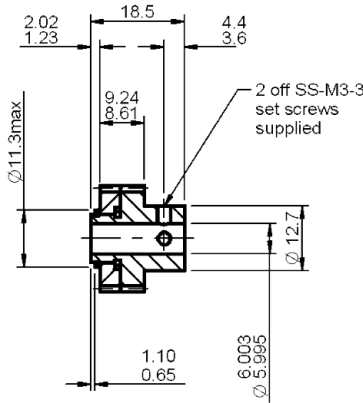

Part number selection table

Example Part No:- [AH25MS2B6F89A- 20](#)













Basic Part Number	Circular Pitch (mm)	Bore Size	Number of Teeth	
			Min	Max
AH1MS2B6F89A-	1	6	46	54
AH2MS2B6F89A-	2		24	26
AH25MS2B6F89A-	2.5		20	20
AH1MS2B10F89A-	1	10	87	104
AH2MS2B10F89A-	2		45	51
AH25MS2B10F89A-	2.5		37	40

i Features and options

- Standard accuracy AQ10 - see [page T4-1](#)
- Higher accuracies available
- Ideal for use with Reliance soft and hardened, round and rectangular racks
- Ideal for lightly loaded measurement applications
- Alternative pitches available
- Alternative bore sizes, including imperial available
- Alternative materials available
- Special wear resistant coating available
- For modified or fully bespoke pinions, please contact us





	<i>Introduction to Reliance</i>	<i>i</i>
	<i>Systems Overview</i>	<i>1</i>
	Intelligent Motors and Motorised Actuators	2
	Planetary and Right Angle Gearboxes	3
	Brass, Ground and Precision Spur Gears	4
	Worms and Wheels, Bevels and Internal Gears	5
	Round and Rectangular Racks and Pinions	6
	Leadscrews and Leadscrew Assemblies	7
	Flexible Shaft Couplings, Clutches and Collars	8
	Linear Guides and Slides	9
	Belts and Pulleys	10
	Gear Clamps and Accessories	11
	Bearings and Spacers	12
	Machine Screws, Dowel Pins and Hardware	13
	<i>Technical Information</i>	<i>14</i>
	<i>Appendices and Index</i>	<i>15</i>

Systems Overview	1
Intelligent Motors and Motorised Actuators	2
Planetary and Right Angle Gearboxes	3
Brass, Ground and Precision Spur Gears	4
Worms and Wheels, Bevels and Internal Gears	5
Round and Rectangular Racks and Pinions	6
Leadscrews and Leadscrew Assemblies	7
Flexible Shaft Couplings, Clutches and Collars	8
Linear Guides and Slides	9
Belts and Pulleys	10
Gear Clamps and Accessories	11
Bearings and Spacers	12
Machine Screws, Dowel Pins and Hardware	13
Technical Information	14

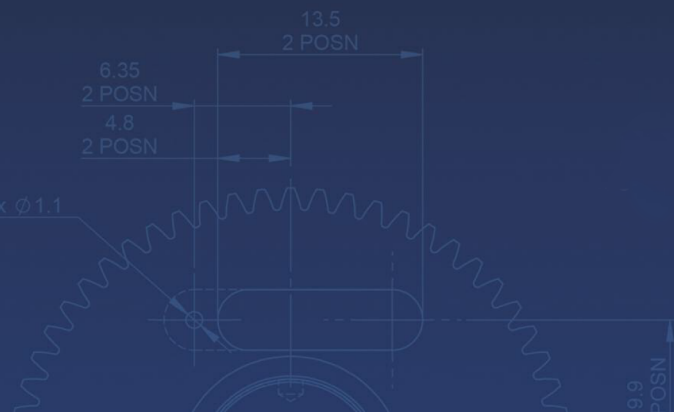

RELIANCE
PRECISION

Rowley Mills, Penistone Road, Lepton
Huddersfield, HD8 0LE, England

+44 (0) 1484 601002
www.reliance.co.uk
sales@reliance.co.uk

RG36 Issue B2 - May 21