

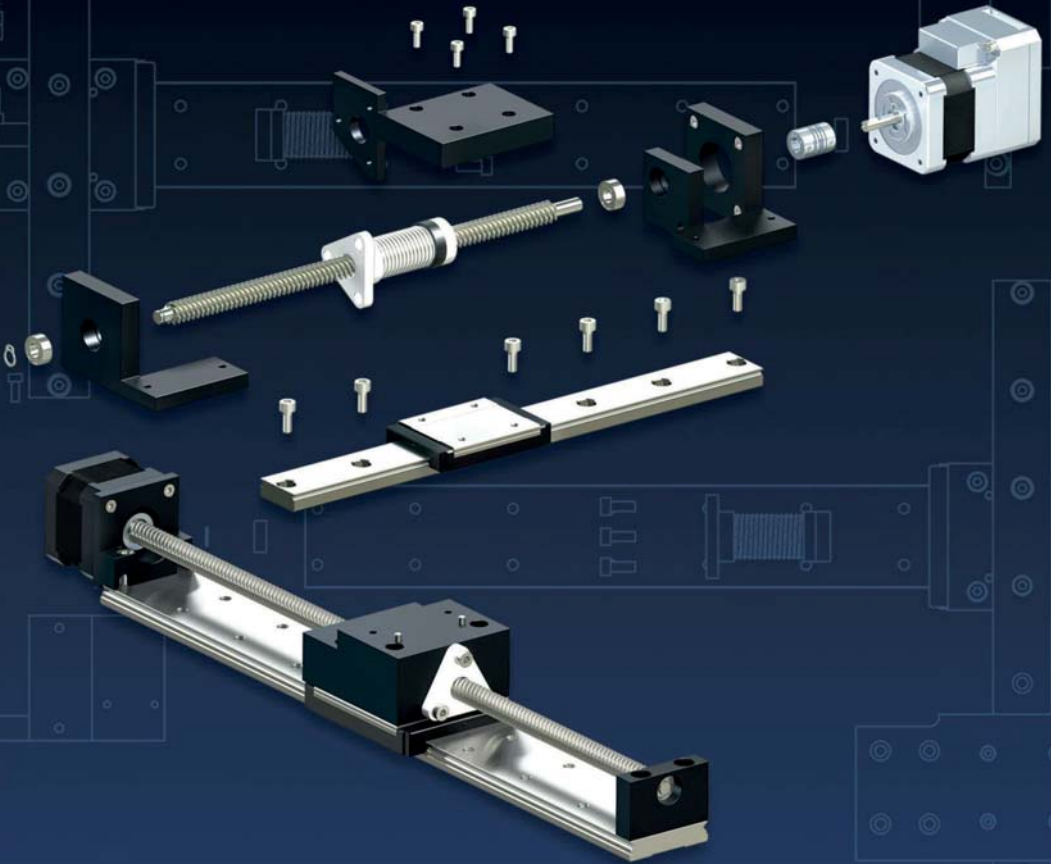



# Reliance<sup>®</sup> Precision Limited



**Precise Motion Control Solutions**  
**Gear Clamps and Accessories**

	<i>Introduction to Reliance</i>	<i>i</i>
	<i>Systems Overview</i>	<i>1</i>
	<b>Intelligent Motors and Motorised Actuators</b>	<b>2</b>
	<b>Planetary and Right Angle Gearboxes</b>	<b>3</b>
	<b>Brass, Ground and Precision Spur Gears</b>	<b>4</b>
	<b>Worms and Wheels, Bevels and Internal Gears</b>	<b>5</b>
	<b>Round and Rectangular Racks and Pinions</b>	<b>6</b>
	<b>Leadscrews and Leadscrew Assemblies</b>	<b>7</b>
	<b>Flexible Shaft Couplings, Clutches and Collars</b>	<b>8</b>
	<b>Linear Guides and Slides</b>	<b>9</b>
	<b>Belts and Pulleys</b>	<b>10</b>
	<b>Gear Clamps and Accessories</b>	<b>11</b>
	<b>Bearings and Spacers</b>	<b>12</b>
	<b>Machine Screws, Dowel Pins and Hardware</b>	<b>13</b>
	<i>Technical Information</i>	<i>14</i>
	<i>Appendices and Index</i>	<i>15</i>



# Section Contents

Shafts - Ground Stock .....Page 11-2

Shaft Retaining Collars .....Page 11-3

Gear Clamps .....Page 11-4

Gear Clamps - Low Inertia .....Page 11-5

Gear and Dial Hubs - Pin Type .....Page 11-6

Gear and Dial Hubs- Clamp Type .....Page 11-7

All dimensions in mm  
 General tolerances  $\pm 0.13$  mm  
 Material: Stainless steel 303 series  
 Straightness: 0.0003 mm/mm  
 Surface finish: 0.25  $\mu$ m

**Associated Products**  
 Shaft collars: page 11-3  
 Bearings: page 12-2  
 Couplings: page 8-1

## Cut to Length

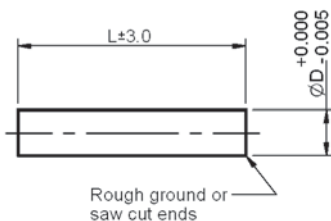

## Machined to Length

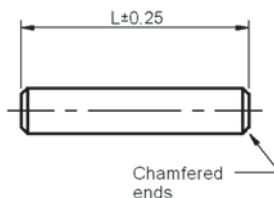

### Part number selection table - Cut to length

Basic Part Number	Diameter $\varnothing D$	Length L	Basic Part Number	Diameter $\varnothing D$	Length L
SM1-3-	2.993	600	SM1-6A-	6.000	600
SM1-3A-	3.000		SM1-8-	7.993	
SM1-4-	3.993		SM1-8A-	8.000	
SM1-4A-	4.000		SM1-10-	9.993	1,000
SM1-5A-	5.000		SM1-10A-	10.000	
SM1-6-	5.993		SM1-12-	11.993	
			SM1-12A-	12.000	

To complete the part number add length details to part number eg **SM1-8-600**

### Part number selection table - Machined to length

Basic Part Number	Diameter $\varnothing D$	Available Lengths					
		Length L	Length Code	Length L	Length Code	Length L	Length Code
SM2-3 SM2-4 SM2-6 SM2-8 SM2-10 SM2-12	2.993 3.993 5.993 7.993 9.993 11.993	25	-25	70	-70	115	-115
		30	-30	75	-75	120	-120
		35	-35	80	-80	125	-125
		40	-40	85	-85	150	-150
		45	-45	90	-90	175	-175
		50	-50	95	-95	200	-200
		55	-55	100	-100	225	-225
		60	-60	105	-105	250	-250
		65	-65	110	-110	275	-275

To complete the part number add length details to part number eg **SM2-8-250**

### **i** Product options

- Standard shaft end modifications, similar to those on leadscrews, are available - see [page 7-27](#)
- Imperial sizes available

# Shaft Retaining Collars

## Associated Products

Hubless gears: page 4-52

Hubless brass gears: page 4-78

Shafts: page 11-2

Bearings: page 12-2

All dimensions in mm  
 General tolerances  $\pm 0.13$  mm  
 Material: Stainless steel  
 303S31 or 303S21

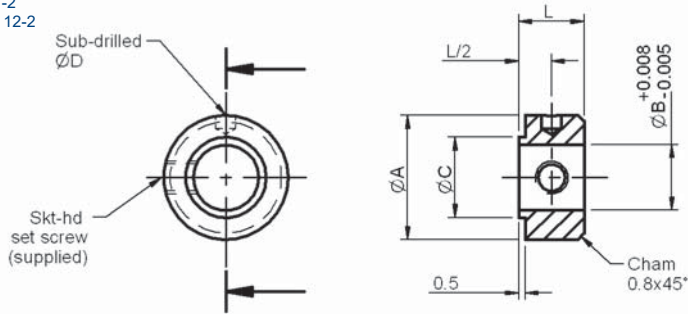

## Part number selection table

Part Number	Bore ØB	Length L	Outer Dia ØA	Shoulder Dia ØC	Sub-drill ØD	Set Screw Supplied
<b>CSM-2</b>	2.0	5.0	7.0	3.0	0.75	SS-M1.6-2
<b>CSM-3</b>	3.0	5.0	8.0	4.1	0.75	SS-M2-2
<b>CSM-4</b>	4.0	5.0	8.0	5.3	1.00	SS-M2-2
<b>CSM-5</b>	5.0	6.0	10.0	6.7	1.20	SS-M3-3
<b>CSM-6</b>	6.0	6.0	10.0	7.9	1.50	SS-M3-3
<b>CSM-8</b>	8.0	6.0	12.0	10.2	1.80	SS-M4-4
<b>CSM-10</b>	10.0	10.0	19.0	12.3	3.00	SS-M5-4
<b>CSM-12</b>	12.0	11.0	25.0	15.2	3.00	SS-M6-6

## **i** Product options

- Imperial sizes available

All dimensions in mm  
 General tolerances  $\pm 0.13$  mm  
 Material: Stainless steel, 303S21

**Associated Products**  
 Clamp hub gears: from page 4-36  
 Anti-backlash gears: from page 4-22

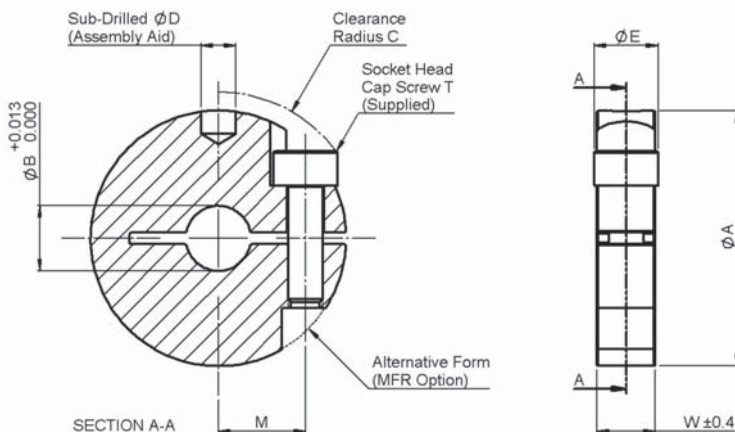

## Part number selection table

Part Number	To Suit Gear of Bore Dia	Bore $\varnothing B$	Outer Dia $\varnothing A$	Width $W$	Head Dia $\varnothing E$ (max)	Clearance Radius $C$	Screw Supplied $T$	Screw Offset $M$	Sub-drill $\varnothing D$
CGM1-2	2	3.6	16.0	4.0	3.8*	8.7	M2	5.3	1.5
CGM1-3	3	4.6							
CGM1-4	4	5.6							
CGM1-5	5	6.6	22.0	5.0	5.5	12.8	M3	7.5	3.0
CGM1-6	6	7.6							
CGM1-8	8	9.6	29.0	6.0	7.0	17.1	M4	9.5	4.0
CGM1-10	10	11.6							
CGM1-12	12	13.6							

\* Socket head on these components is narrower than the clamp

## **i** Product options

- Imperial sizes available



# Gear Clamps - Low Inertia

## Associated Products

Clamp hub gears: from page 4-36  
 Anti-backlash gears: from page 4-22  
 Anti-backlash pinions: page 4-7

All dimensions in mm  
 General tolerances  $\pm 0.13$  mm  
 Material: Aluminium alloy, EN AW-2014-T6511 or L168  
 Finish: Chromic acid anodise to DEF STAN 03-24

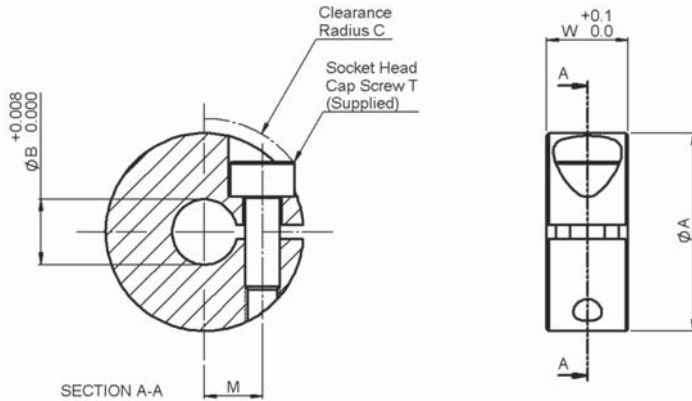

## Part number selection table

Part Number	To Suit Gear of Bore Dia	Bore ØB	Outer Dia ØA	Width W	Clearance Radius C	Screw Supplied T	Screw Offset M
<a href="#">CGAM-2A</a>	2	3.6	12.0	5.0	7.2	M2	3.5
<a href="#">CGAM-3A</a>	3	4.6	13.0		7.8		4.0
<a href="#">CGAM-4A</a>	4	5.6	17.0	7.0	10.0	M3	5.0
<a href="#">CGAM-5A</a>	5	6.6	18.0		10.6		5.5
<a href="#">CGAM-6A</a>	6	7.6	19.0		11.3		6.2
<a href="#">CGAM-8A</a>	8	9.6	24.0	9.0	13.8	M4	7.5
<a href="#">CGAM-10A</a>	10	11.6	26.0		14.8		8.5
<a href="#">CGAM-12A</a>	12	13.6	28.0		16.2		9.8

## **i** Product options

- Imperial sizes available

Gear Clamps & Accessories



All dimensions in mm  
General tolerances  $\pm 0.13$  mm  
Material: Stainless steel

**Associated Products**  
Hubless gears: page 4-52  
Hubless brass gears: page 4-78

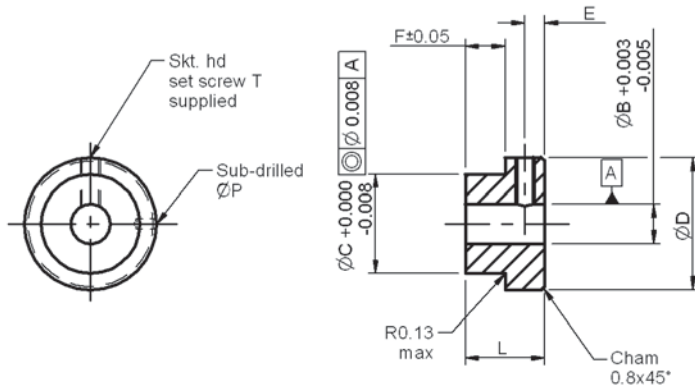

## Part number selection table - Dial hubs

Part Number	Bore $\varnothing B$	Face F	Length L	Outer Diameter $\varnothing D$	Mount Diameter $\varnothing C$	Sub-drill $\varnothing P$	Distance E	Set Screw Supplied T
PHMD-1	3.0		7.2			0.75		SS-M2-2
PHMD-3	4.0	1.57	7.2	11.0	9.52	1.00	2.8	SS-M2-2
PHMD-5	6.0		8.0			1.50		SS-M3-3

## Part number selection table - Gear hubs

Part Number	Bore $\varnothing B$	Face F	Length L	Outer Diameter $\varnothing D$	Mount Diameter $\varnothing C$	Sub-drill $\varnothing P$	Distance E	Set Screw Supplied T
PHM1-1	3.0	3.0	9.0	12.0	10.0	0.75	3.0	SS-M2-2
PHM1-2		6.0	12.0					
PHM1-3	4.0	3.0	9.0	12.0	10.0	1.00	3.0	SS-M2-2
PHM1-4		6.0	12.0					
PHM1-5	6.0	3.0	9.0	20.0	15.0	1.50	3.0	SS-M3-3
PHM1-6		6.0	12.0					
PHM1-7	8.0	3.0	12.0	20.0	15.0	1.80	4.5	SS-M4-4
PHM1-8		6.0	15.0					
PHM1-9	10.0	6.0	18.0	30.0	25.0	3.00	6.0	SS-M5-5
PHM1-10		8.0	20.0					
PHM1-11		10.0	22.0					

### **i** Features and options

- Gears, sprockets or dials assembled on request
- Imperial bores available
- Special hubs for Delrin gears

### **?** Technical support

- Recommended assembly procedure: Notch and stake in 4 equi-spaced positions and/or use adhesive (Loctite grade 326)

# Gear and Dial Hubs Clamp Type



**Associated Products**  
 Hubless gears: page 4-52  
 Hubless brass gears: page 4-78

All dimensions in mm  
 General tolerances  $\pm 0.13$  mm  
 Material: Stainless steel

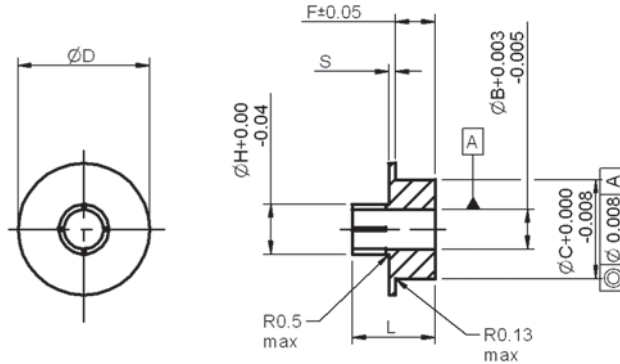

## Part number selection table - Dial hubs

Part Number	Bore $\varnothing B$	Face F	Length L	Outer Diameter $\varnothing D$	Mount Diameter $\varnothing C$	Hub Diameter $\varnothing H$	Shoulder S	To Suit Clamp
<b>CHMD-1</b>	3.0	1.57	8.7	12.0	9.52	4.6	1.0	CGM1-3
<b>CHMD-3</b>	4.0			5.6		CGM1-4		
<b>CHMD-5</b>	6.0			7.6		CGM1-6		

## Part number selection table - Gear hubs

Part Number	Bore $\varnothing B$	Face F	Length L	Outer Diameter $\varnothing D$	Mount Diameter $\varnothing C$	Hub Diameter $\varnothing H$	Shoulder S	To Suit Clamp
<b>CHM1-1</b>	3.0	3.0	8.5	12.0	10.0	4.6	1.0	CGM1-3
<b>CHM1-2</b>		6.0	11.5					
<b>CHM1-3</b>	4.0	3.0	9.5	12.0	10.0	5.6	1.0	CGM1-4
<b>CHM1-4</b>		6.0	12.5					
<b>CHM1-5</b>	6.0	3.0	9.5	20.0	15.0	7.6	1.0	CGM1-6
<b>CHM1-6</b>		6.0	12.5					
<b>CHM1-7</b>	8.0	3.0	11.0	20.0	15.0	9.6	1.5	CGM1-8
<b>CHM1-8</b>		6.0	14.0					
<b>CHM1-9</b>	10.0	6.0	14.0	30.0	25.0	11.6	1.5	CGM1-10
<b>CHM1-10</b>		8.0	16.0					
<b>CHM1-11</b>		10.0	18.0					









### **i** Features and options

- Gears, sprockets or dials assembled on request
- Imperial bores available
- Special hubs for Delrin gears

### **?** Technical support

- Recommended assembly procedure: Notch and stake in 4 equi-spaced positions and/or use adhesive (Loctite grade 326)

Gear Clamps & Accessories

	<i>Introduction to Reliance</i>	<i>i</i>
	<i>Systems Overview</i>	<i>1</i>
	<b>Intelligent Motors and Motorised Actuators</b>	<b>2</b>
	<b>Planetary and Right Angle Gearboxes</b>	<b>3</b>
	<b>Brass, Ground and Precision Spur Gears</b>	<b>4</b>
	<b>Worms and Wheels, Bevels and Internal Gears</b>	<b>5</b>
	<b>Round and Rectangular Racks and Pinions</b>	<b>6</b>
	<b>Leadscrews and Leadscrew Assemblies</b>	<b>7</b>
	<b>Flexible Shaft Couplings, Clutches and Collars</b>	<b>8</b>
	<b>Linear Guides and Slides</b>	<b>9</b>
	<b>Belts and Pulleys</b>	<b>10</b>
	<b>Gear Clamps and Accessories</b>	<b>11</b>
	<b>Bearings and Spacers</b>	<b>12</b>
	<b>Machine Screws, Dowel Pins and Hardware</b>	<b>13</b>
	<i>Technical Information</i>	<i>14</i>
	<i>Appendices and Index</i>	<i>15</i>

Systems Overview	1
Intelligent Motors and Motorised Actuators	2
Planetary and Right Angle Gearboxes	3
Brass, Ground and Precision Spur Gears	4
Worms and Wheels, Bevels and Internal Gears	5
Round and Rectangular Racks and Pinions	6
Leadscrews and Leadscrew Assemblies	7
Flexible Shaft Couplings, Clutches and Collars	8
Linear Guides and Slides	9
Belts and Pulleys	10
Gear Clamps and Accessories	11
Bearings and Spacers	12
Machine Screws, Dowel Pins and Hardware	13
Technical Information	14

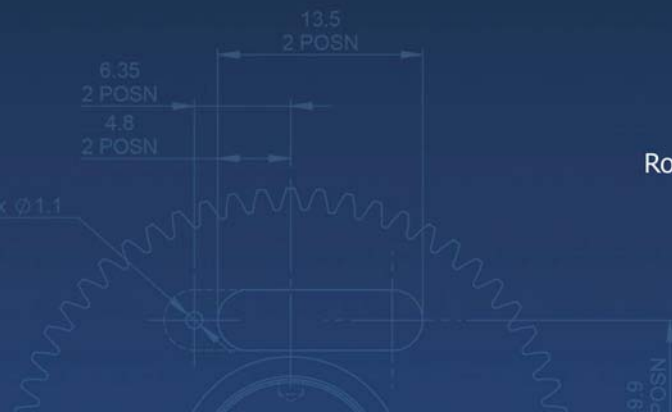

Rowley Mills, Penistone Road, Lepton  
Huddersfield, HD8 0LE, England

+44 (0) 1484 601002

[www.reliance.co.uk](http://www.reliance.co.uk)

[sales@reliance.co.uk](mailto:sales@reliance.co.uk)

RG36 Issue A2